

KITCHEN EXTRACT

---

# ESP RANGE

---

1500 | 3000 | 4500 | 6000

*Saubere Luft mit ...*  
**InoxAir®**

purified<sup>air</sup>®

# COMMERCIAL KITCHEN FILTRATION EXPERTS

Purified Air Ltd. has been manufacturing and servicing market-leading technology to filter and control oil, grease, smoke and odour from commercial kitchens since 1984.

## CONTENTS

02

### TECHNICAL OVERVIEW

Key Features	02
ESP Technology	03
How It Works	04
Benefits of ESP	05
Technical Specification	06

08

### ESP AUTOWASH

Key Features	09
How It Works	10
Technical Specification	11

12

### ABOUT US

An Overview	
Our Coverage	

09

### GET IN TOUCH

Contact Details	
-----------------	--

## KITCHEN EXTRACT

# ESP RANGE

1500 | 3000 | 4500 | 6000



Our ESPs have been specifically designed for kitchen extract systems; they have integral sumps to collect the oil, grease and smoke particles filtered out of the exhaust.

This not only simplifies servicing but eradicates potentially dangerous spillage from the bottom of the units and greatly cuts down on build-ups of grease within the ducting.

The ionisation voltage has been designed to run at a negative potential which enhances the ionisation of particles and also produces more ozone which is helpful in reducing cooking odours.

## KEY FEATURES

- Eliminates up to 98% of oil, grease and smoke particles
- Filters particles down to sub-micron levels
- Produces Ozone to help reduce malodours
- Designed with an integral sump
- Modular in design
- Specifically designed for commercial kitchen application
- Energy efficient: - uses no more than 50W
- Greatly reduces grease build-up within the duct run
- IP65 rated for outside location

## FILTERS REMOVE



Smoke



Steam



Oil



Grease

# HOW IT WORKS

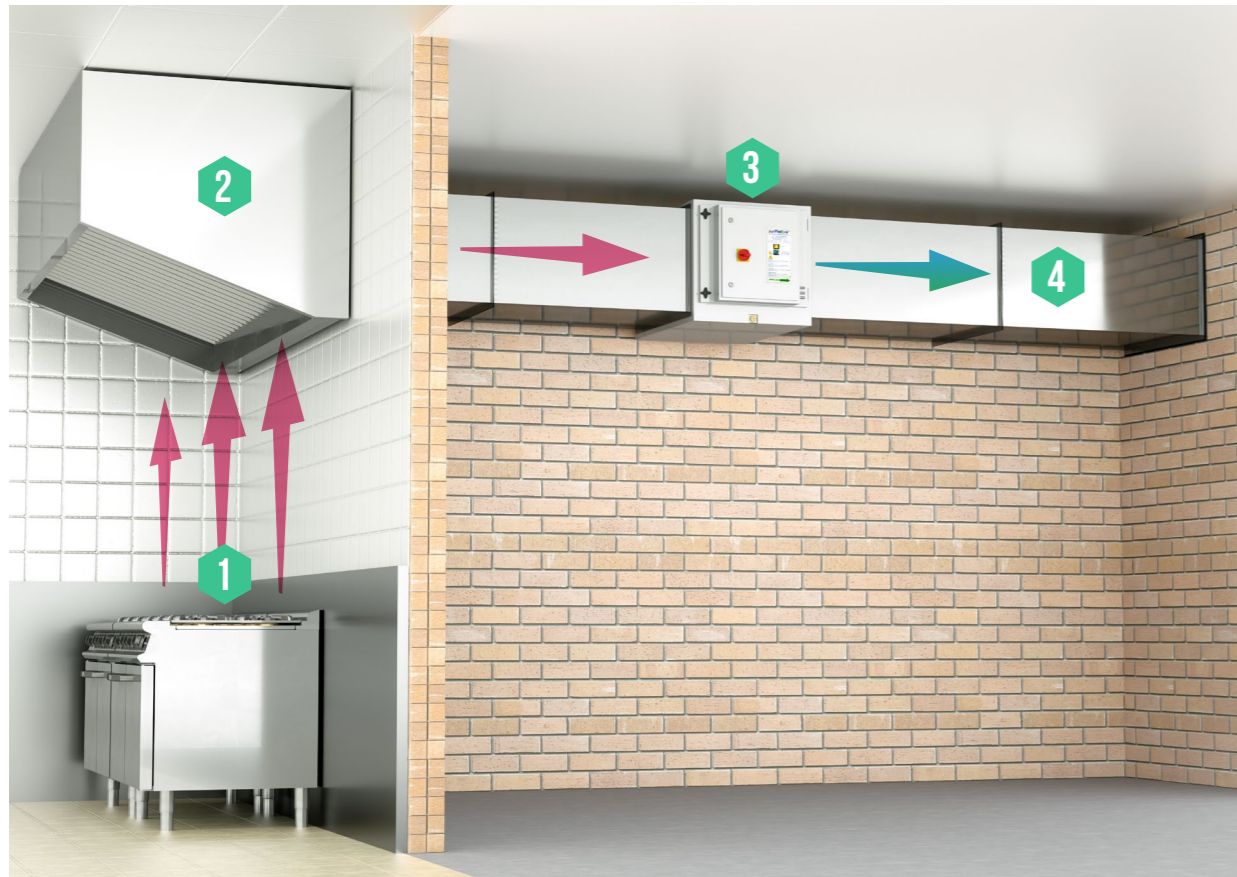

Our ESP units fit in-line with the kitchen ducting and can be configured modularly to cope with all extract volume requirements.

- 01** Cooking particulates and odours

**02** Canopy Grease Filter
- 03** ESP - Particulate Control Unit

**04** Airflow

## OUR SERVICES



Design



Manufacture



Maintain

# THE ELECTROSTATIC PROCESS

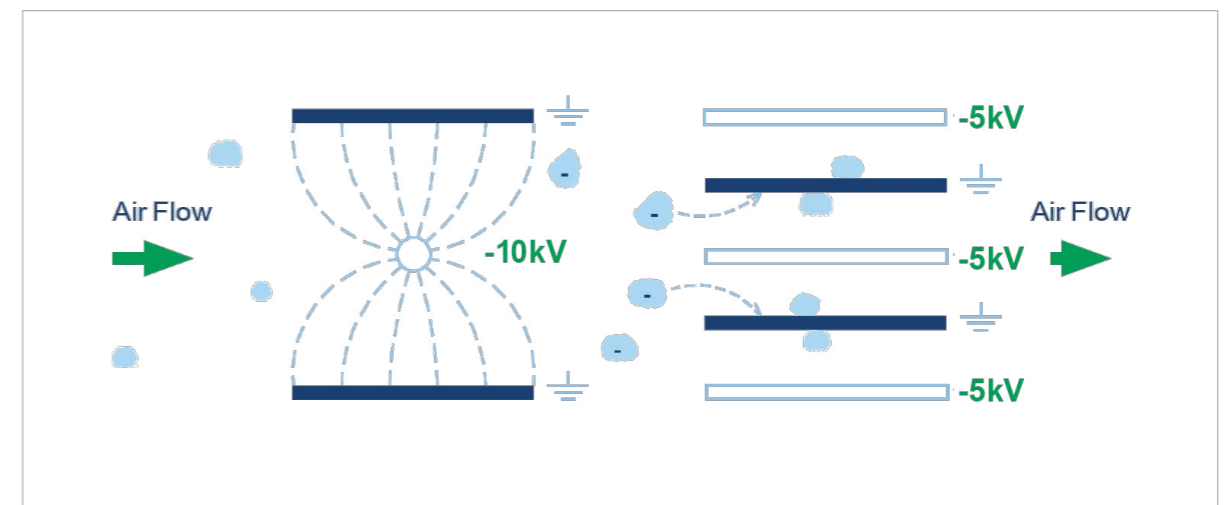

The above diagram shows, in a basic visual, how an electrostatic precipitator works:

As air passes into the combined ioniser / collector cell, the particulates in the air stream are polarised. As they continue through the ioniser and between the collector cell plates,

the polarised particulates are repelled away from the negatively charged plates and attracted to the earthed plates where they stick and so are filtered out of the air flow.

## THE BENEFITS OF ELECTROSTATIC TECHNOLOGY



Eliminates up to 99% of particles



Filters particles down to sub-micron levels



Modular design



Energy efficient

## TECHNICAL SPECIFICATION

	ESP 1500	ESP 3000	ESP 4500	ESP 6000
Supply	220-240 <sub>V</sub> 50HZ	220-240 <sub>V</sub> 50HZ	220-240 <sub>V</sub> 50HZ	220-240 <sub>V</sub> 50HZ
Power Consumption	20 <sub>w</sub>	30 <sub>w</sub>	40 <sub>w</sub>	50 <sub>w</sub>
Maximum Airflow	0.7 <sub>M<sup>3</sup>/SEC</sub> (UP TO)	1.4 <sub>M<sup>3</sup>/SEC</sub> (UP TO)	2.1 <sub>M<sup>3</sup>/SEC</sub> (UP TO)	2.8 <sub>M<sup>3</sup>/SEC</sub> (UP TO)
Dimensions (mm)	W 450 H 630 D 640	W 900 H 630 D 640	W 1350 H 630 D 640	W 1800 H 630 D 640
Weight	55 <sub>KG</sub>	85 <sub>KG</sub>	118 <sub>KG</sub>	153 <sub>KG</sub>

## DRAWINGS

### ESP 1500

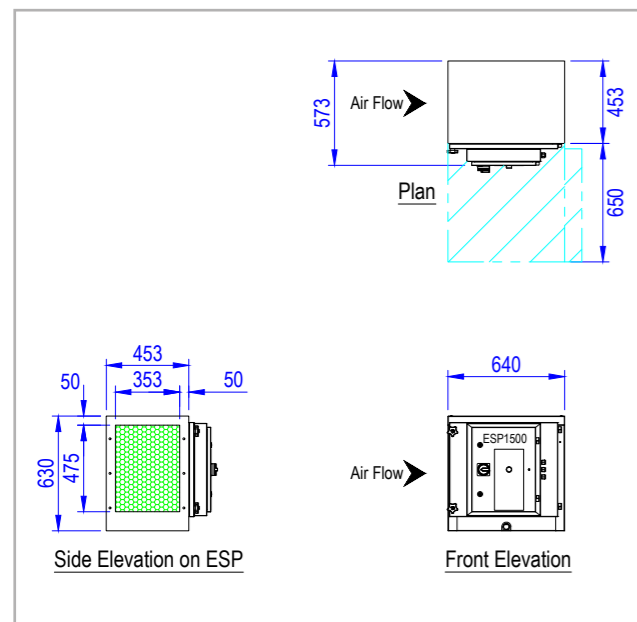

### ESP 3000

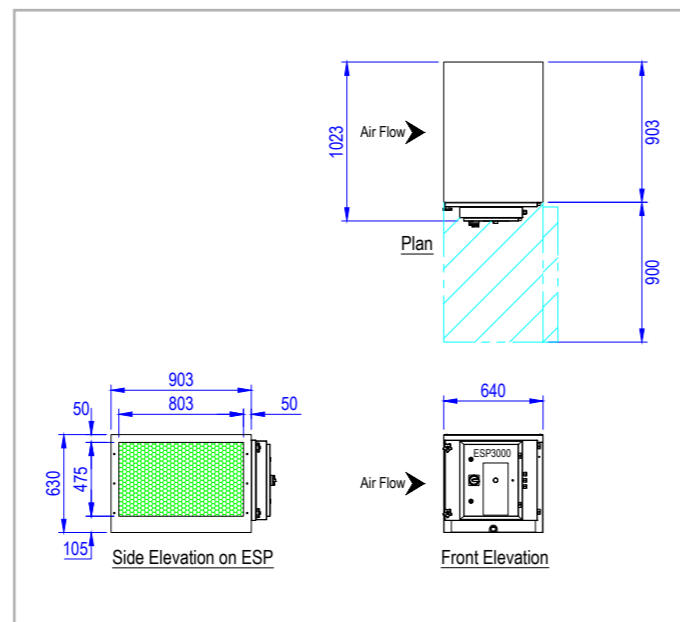

### ESP 4500

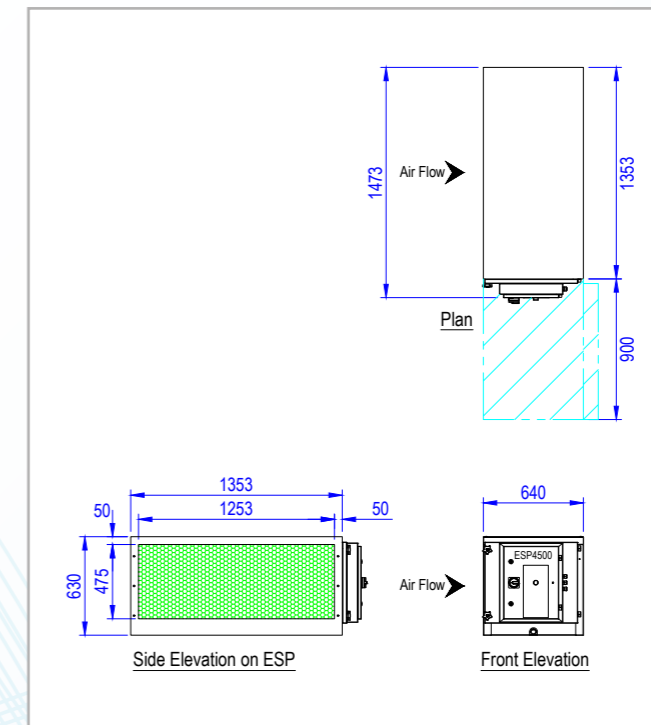

### ESP 6000

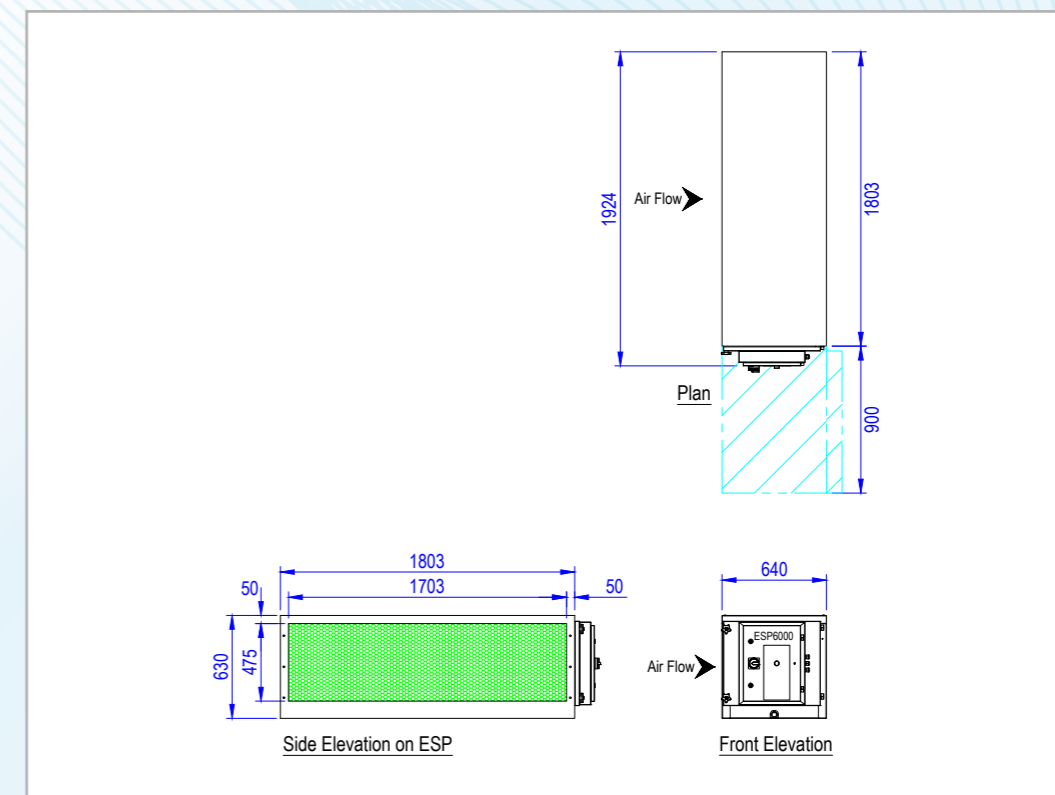

KITCHEN EXTRACT

# ESP AUTOWASH



The ESP Autowash system was first made available in 2012. Since then, we have continually developed the product to make it a cost-effective way of cleaning the ESP interior. This reduces the frequency of required manual service visits which provides

long-term savings for the customer. In addition, the straightforward setup and option for retrofitting to existing Purified Air ESP systems mean the Autowash is easy to install.

## KEY FEATURES

The control, detergent and water supply is housed in one control station which is placed next to the ESP unit(s). One control station can operate up to six ESP units but is also cost effective when only used with a single ESP. The main control is a PLC and this can be programmed to suit the number of ESP units and it will initiate a timed rinse, wash and dry program whilst it locks out the supply to the ESP unit(s). The wash program can be initiated manually or on a timed basis when the extract system is not in operation.

The system comes fitted with a warning indicator lamps to notify the user when there is a system fault and when the unit is operational. These controls can be wired to work autonomously or via a building management system (BMS).

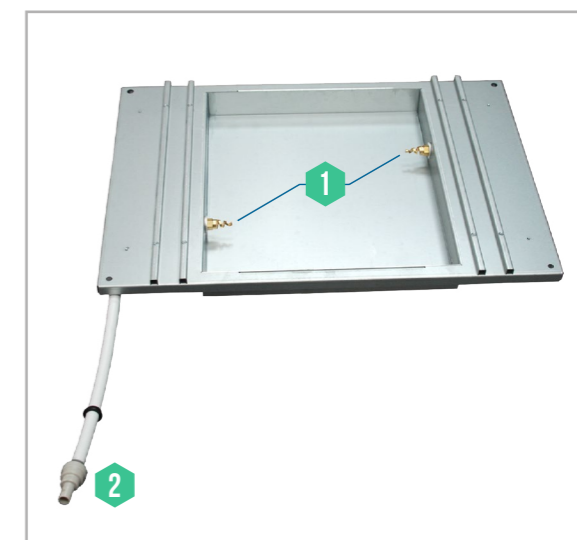

01 Wash nozzles

02 Supply pipe

### NOZZLE ATTACHMENT

Each ESP unit has a bespoke nozzle attachment which is pre piped with two wash nozzles per collector. These are fitted in place of the standard top filter guide and can also be easily retro fitted to any post 2015 unit.

### SERVICING

The Autowash system is designed to reduce manual maintenance manual maintenance visits, not replace them altogether. Collectors should still be checked and manually washed approximately once every three months. Mesh filters need to be checked monthly.

# HOW IT WORKS

Start either manually or by pre-programmed 24 hour timer. There is an interface to cut-off the ESP and main extract fan and a 60 sec delay to allow the ESP to discharge and extract fan to stop.

	DURATION		DURATION		
01	Pre-wash with hot water on the collection cells	20s	06	Stop & drip dry	15s
02	Stop drip dry	15s	07	Detergent Spray	30s
03	Detergent spray	30s	08	Stop & detergent reaction	60s
04	Stop & detergent reaction	60s	09	Rinse	20s
05	Rinse	20s	10	Stop & drip dry	120s

**Re-start extract fan for forced drying for 60mins**  
Re-start complete system back to normal working operation.

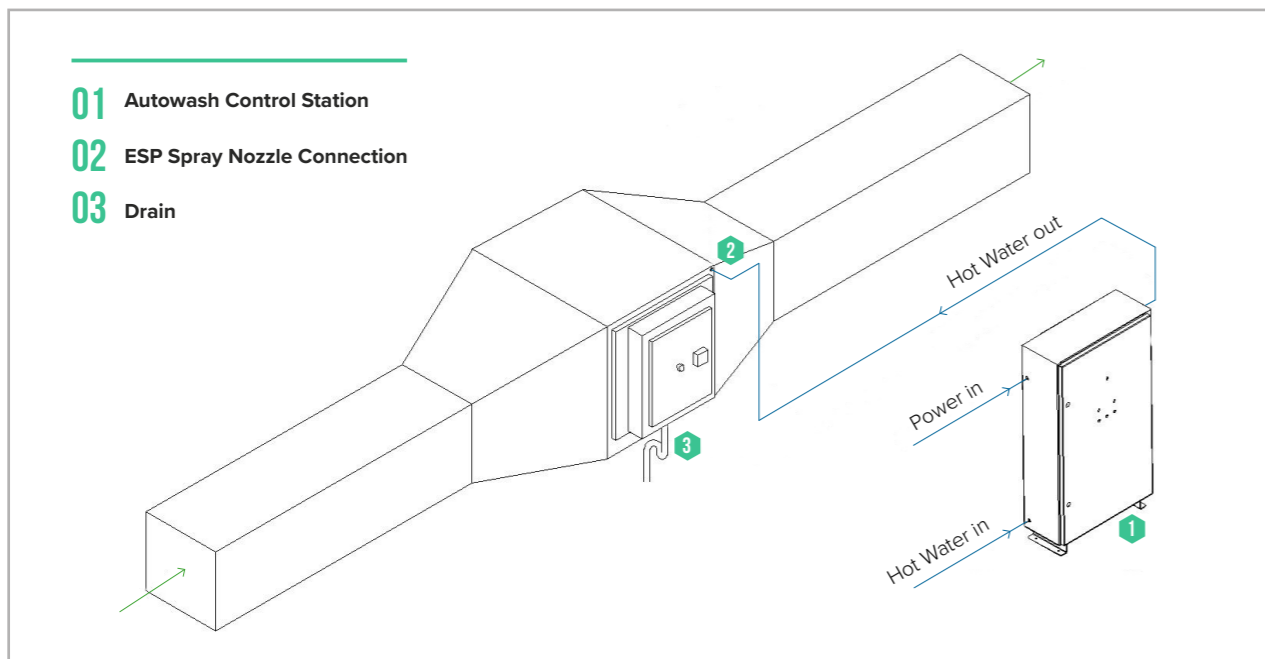
## TECHNICAL SPECIFICATION

Autowash	
Wash Cycle Power Usage	35W
Electrical Supply	220/240V/1Ph/50Hz
Water Supply	24 litres/minute
Weight	40 kg
Water Pressure	2 bar
Dimensions	Width: 600mm
	Depth: 250mm
	Height: 1075mm

## TECHNICAL DRAWINGS



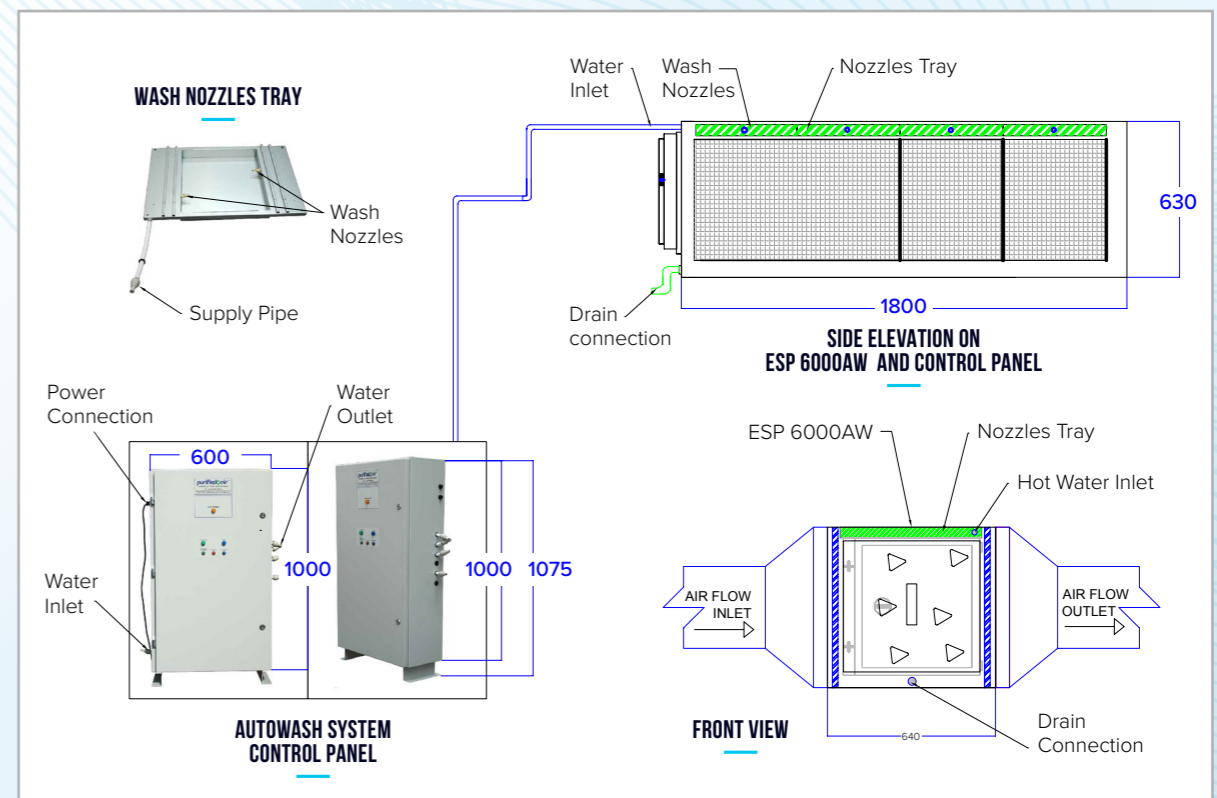

## ABOUT US

Purified Air Ltd. has been striving to find the best and most cost-effective way to filter and control oil, smoke, fat and odour produced by commercial kitchens and service since 1984.

Purified Air manufactures filtration and odour control products for stock and bespoke systems, supplying systems to many sectoral brands. The design of each solution is based on the type of food cooked, the cooking process used, and the extracted air volume providing tried and tested purified kitchen exhaust air for Fast Food, Casual Dining and Luxury Concept Restaurant (Fine Dining) markets. By working with these variables, we can design and supply some of the world's best commercial kitchen filtration and odour control systems.

### WORLDWIDE COVERAGE

- United Kingdom
- Middle East
- Europe
- Asia
- Australasia
- North America

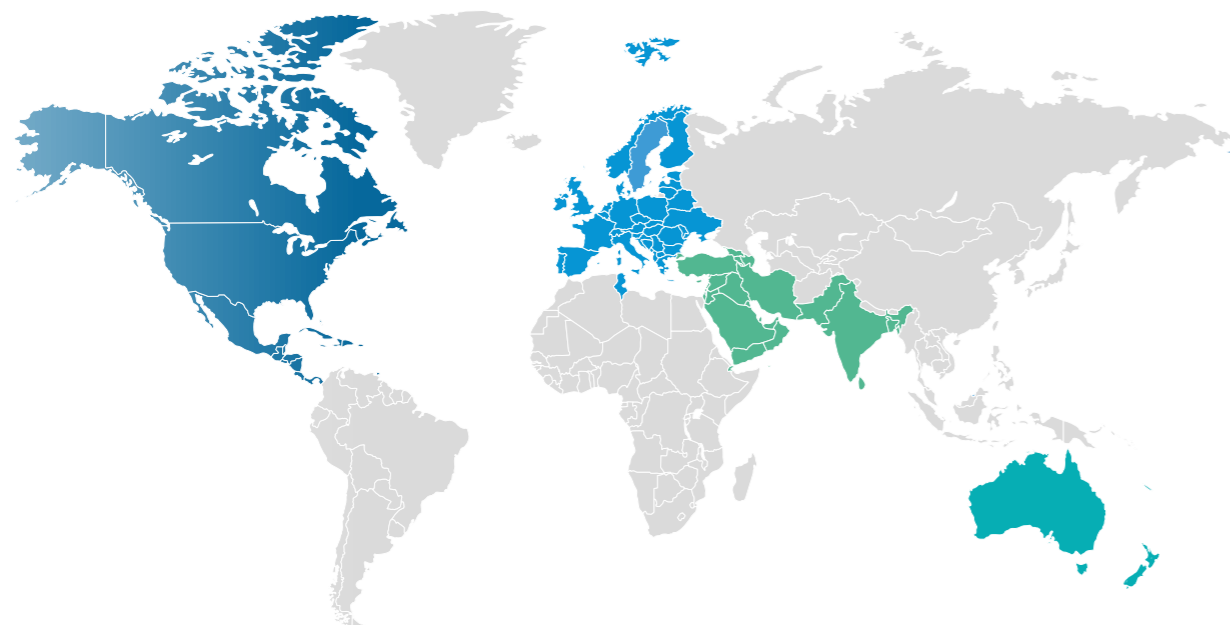

# GET IN TOUCH

☎ 01708 755 414

✉ [enq@purifiedair.com](mailto:enq@purifiedair.com)

📍 Purified Air Limited, Lyon House  
Lyon Road, Romford,  
Essex RM1 2BG

[purifiedair.com](http://purifiedair.com)

purifiedair®

---

[purifiedair.com](http://purifiedair.com)

---

*Saubere Luft mit ...*  
**InoxAir®**

---

[inoxair.de](http://inoxair.de)

---